

BFLANcore

Blackfin board for μ CLinux and VisualDSP with built in LAN based on a BF537 and a Spartan3E FPGA



The **BFLANcore** board is a micro system based on Analog Devices' Blackfin family. A single BF537 capable of running μ CLinux with Ethernet MAC and on-board PHY in combination with a Xilinx Spartan3E FPGA makes up a complete high performance DSP controller board for all sorts of embedded applications.

With a size of only 1.05" x 1.8", the board will fit every embedded platform. High density connectors (.8mm pitch) provide access to 33 general purpose (incl. 11 LVDS pairs) plus a number of DSP I/O signals as well as LAN and JTAG signals for both DSP and FPGA.

The BF537 can boot via TFTP over the network and load configuration data to the FPGA. Alternatively, the board can be booted from an on-board serial flash.

The only power supply required is a 3.3Volt .4 Amps rail. The core voltages for the Blackfin and the FPGA are generated on board.

Example projects for VisualDSP and μ CLinux are available with the hardware, demonstrating how to start up the Blackfins and launch applications.

A motherboard for one **BFLANcore** board with many I/O signals accessible at 100mil header plus JTAG headers for easy evaluation, a suitable power supply and JTAG headers is available on request.

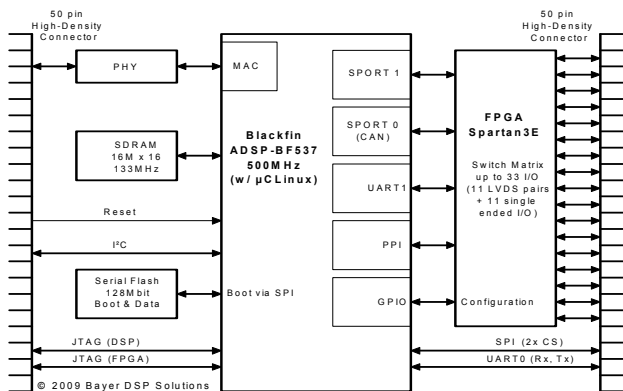
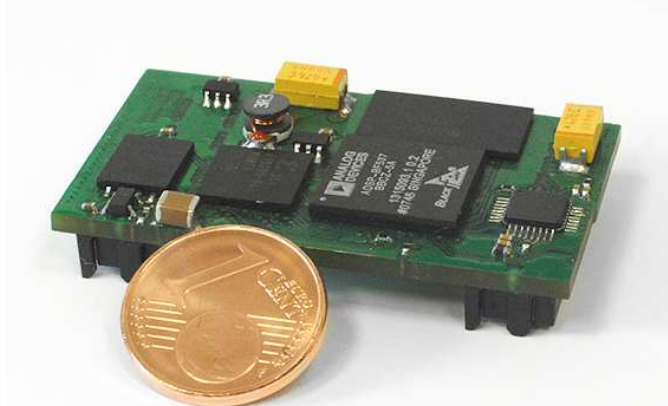

Specifications:

Power consumption: <1.5 Watts @ 3.3V

Memory: up to 32MB SDRAM, up to 64 Mb serial flash

I/O: Up to 33 general purpose I/O pins including the DSP's I²C, SPI, UARTs, SPORTs and PPI

Processor: ADSP-BF537-BBCZ5A or -KBCZ6A

FPGA: Xilinx Spartan 3E XC3S100E or XC3S500E

Physical Dimensions: 45,5mm x 26,5 mm x 13mm (including connectors)

Pricing: please call

All prices are excluding VAT, packaging and shipping.

Ingenieurbüro Bayer DSP Solutions

Ingenieurbüro Bayer DSP Solutions was founded in 1995 by Andreas Bayer, a first hour DSP specialist. The company has been a third party of several DSP vendors since 1996.

Our goal is to provide comprehensive coverage of all Digital Signal Processing topics, including hardware design, FPGA design, DSP algorithms, software integration, tools and complete products.

We support many DSP families including Texas Instruments C54x, C55x, C3x, C6x, Analog Devices ADSP-218x, SHARC and Blackfin, Freescale DSP56K as well as DSPs from other vendors, ARM, PIC, MSP430 and Xilinx FPGA.

Our products are sold through
A.R. Bayer DSP Systeme GmbH (www.dsp-sys.de).

A.R. Bayer DSP Systeme GmbH provides JTAG emulation solutions for Texas Instruments DSP by EWA, Inc. (www.blackhawk-dsp.com) as well as boundary scan test systems by Corelis (www.corelis.com) and complex DSP/FPGA boards by Sundance (www.sundance.com).



Ingenieurbüro Bayer DSP Solutions
Andreas R. Bayer
Vohwinkelallee 8
40229 Düsseldorf / Germany
Phone: +49-211-210 81 20
Fax: +49-211-210 81 76
Email: solutions@dsp-bayer.de
Web: <http://www.dsp-bayer.de>